

The Ocee Collection 2020.



ocee
DESIGN

AN OCEE
INTERNATIONAL
COMPANY

The Ocee Collection

Reception & Soft Seating



Noah 06



Harc 08



Harc Booth 10



Harc Modular 12

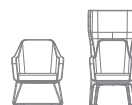

Harc Tub 14



Alfi 16



HenRay 18



FourUs 20

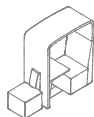

FourLikes 22



Dishy 26



Billo 28



Stretch 30



Skyline 32



Hilly 34

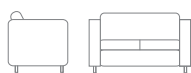

Dorchester 36



Giggle 37



Solace 38



Venus 39



Touch 40



Upholstered Stools 41



Casino 42



Forum 43



The Ernest Race Heritage Collection 45

Workspace & Landscape Furniture

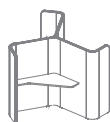

Den 52



FourUs Wall 56



Hotbox 57

Meeting, Conference & Café



FourMe® 64



FourSure® 66



FourCast® 68



Ecolabel Chairs 72



Four® Outdoors 73



Four®Seat Benches & Stools 74



Panache 76



Absolute Meeting & Work Lite 77



Era Meeting & Work Lite 78



Alina 79

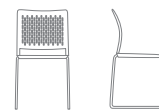











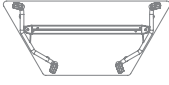





Patch 80



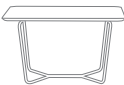













Volee 81

Table Collection

					
Kite® 86	FourMat® 88	FourFold™ 90	FourReal® A 94	FourReal® A 96	FourReal® Flake 98
					
FourReal® Wood 100	FourReal® 741, 74, 90 & 105 with partitions 102	Four® Tables 104	Buddy Power Tables 108	Noah Tables 109	Harc Rectangular Tables 110
					
Harc Tub Tables 111	Dishy Tables 112	Giggle Tables 113	Chai 114	Mocha 114	

Task Collection

					
Absolute 120	Era 121	Airo 121	Harvey 121	Sphere 122	Flexion 122
					
Poise 122	Re-act Deluxe 123	Re-act 123	Re-act Mesh 123	Fusion 124	Tick 124
					
Urban 124	Goal 125	Industrial 125			



ocee INTERNATIONAL

People. Place. Purpose.

A proud international family

Welcome to the Ocee Collection, a brochure which celebrates the portfolio of Ocee Design. As the parent company of acclaimed international furniture brands Ocee Design, Four Design and Race Furniture, we seek to combine the research, design and manufacturing skills of leading furniture companies to create internationally relevant collections of cutting-edge products and services.



ocee
DESIGN

Ocee Design is a UK based manufacturer of commercial furniture working with office furniture resellers, design and build consultants, architects and specifiers. Its portfolio includes soft seating, meeting and conference chairs, acoustic products, tables, task seating and landscape systems.



FOUR
DESIGN

Four Design is a Danish manufacturer specialising in Scandinavian designed furniture, that combines unrivalled functionality with ingenious design. It operates throughout Europe and has manufacturing partners in North America, China and Australia.



race
FURNITURE

Race Furniture has been at the forefront of the design and manufacturing of seating for public spaces for over 70 years. Its bespoke service for theatre, lecture hall and concourse seating has resulted in an impressive international client list. As the custodian of the designs of its founder Ernest Race, it still manufactures classics such as the Antelope, BA3 and DA1 chairs.

ocee
DESIGN

FOUR
DESIGN

race
FURNITURE





Reception & Soft Seating

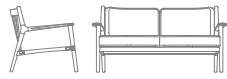

Noah 06



Harc 08



Harc Booth 10



Harc Modular 12



Harc Tub 14



Alfi 16



HenRay 18

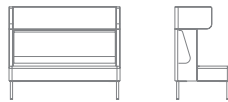

FourUs 20

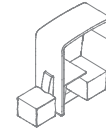

FourLikes 22

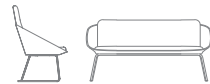

Dishy 26



Billo 28



Stretch 30

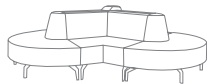

Skyline 32

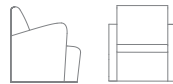

Hilly 34



Dorchester 36



Giggle 37

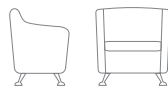

Solace 38



Venus 39



Touch 40



Upholstered Stools 41



Casino 42



Forum 43



The Ernest Race Heritage Collection 45



Noah

Designed by Samuel Wright

Taking its inspiration from domestic interiors, the Noah Collection perfectly suits a relaxed breakout area or lounge. Created in solid wood, Noah celebrates the craft of the British manufacturing industry, using traditional techniques to produce contemporary, timeless pieces.

Features

- Rocker, armchair, sofa and matching table
- Oak and black ash solid wood frames
- Loose cushions
- High density premium quality foam
- Premium quality webbing







Harc Sofas

Designed by Roger Webb Associates

Harc has been created for busy workplaces and collaborative environments, where furniture needs to encourage social interaction, provide meeting areas and a place of refuge to cut out or reduce the surrounding noise.

The name Harc echoes the arc shape with its sweeping curves that wrap around to create a warm and cosy enclosure. The design references back to 1950's styling with characteristically sophisticated low and high back sofas, designed on a variety of leg frames.

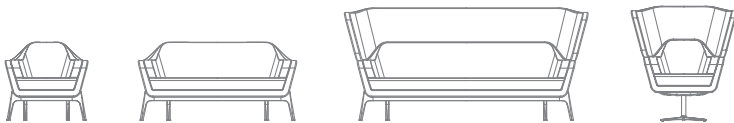

Features

Single seat chair, stool, two and three seat sofa

Low and high back option on all models

Fully webbed seat for additional comfort

Powder coated cast aluminium, chrome and wooden base options

Cast aluminium powder coated legs in a variety of colours

Oak and black ash wooden leg options

Two-tone fabric option

Matching wooden rectangular tables in a wide variety of finishes with wooden, chrome or powder coated legs

Power and data options

Square scatter cushions and bolsters available





Harc Booth

Designed by Roger Webb Associates

The Harc Booth provides the next level of visual and acoustic privacy within the Harc range. A perfect meeting place, the Harc Booth can accommodate AV, power and data.

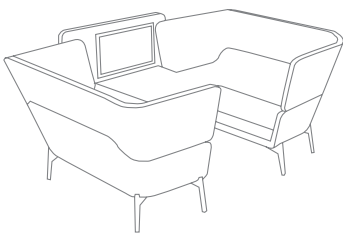

Features

Use with Harc high back two or three seater sofas

Fully webbed seat for additional comfort

Powder coated cast aluminium, chrome and wooden base options

Cast aluminium powder coated legs in a variety of colours

Oak and black oak wooden legs as standard

Power and data options

TV bracket optional

Table tops 25mm MDF core fully laminated

 Powder coating options detailed in the 2020 price list.



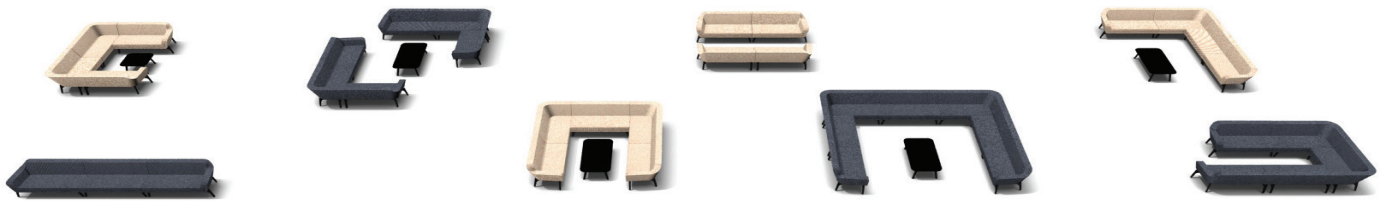

Harc Modular

Designed by Roger Webb Associates

Matching the popular Harc sofa and armchairs, Harc Modular offers the additional flexibility of a low back corner sofa. The number of Harc options, as well as the wide selection of leg finishes and matching tables allows designers to create a sense of harmony across different zones in a building.

Features

- 5 modular pieces
- Matching Harc table collection
- Chrome, powder coated or wood leg options
- Cast aluminium powder coated legs in variety of colours
- Oak and black oak wooden legs as standard
- Two-tone fabric option
- Fully webbed seat for extra comfort
- Power and data options
- Square scatter cushions and bolsters available



 Powder coating options detailed in the 2020 price list.





Harc Tub

Designed by Roger Webb Associates

The two different height Harc Tub chairs offer a lounge chair and a meeting chair scaled for working at a table. With the option of a wraparound acoustic high back, the tub chair becomes a secluded, private place to concentrate, listen and focus on tasks. Three base options offer styles for all environments.

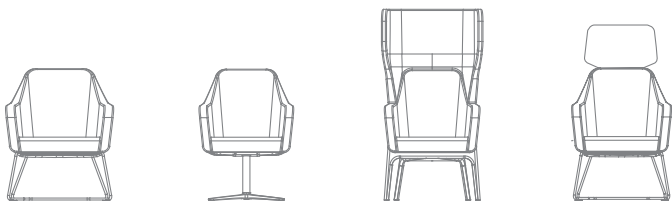

Features

Single seat lounge and meeting tub chairs with matching tables

Low and high back option on all models

Moulded foam for additional comfort and durability

Chrome, oak and black oak leg options as standard

Other wood and powder coated finishes available

Two-tone fabric option

Headrest option for all Harc low back tub chairs and meeting chairs

Matching wooden rectangular tables in a wide variety of finishes with wooden, chrome or powder coated legs



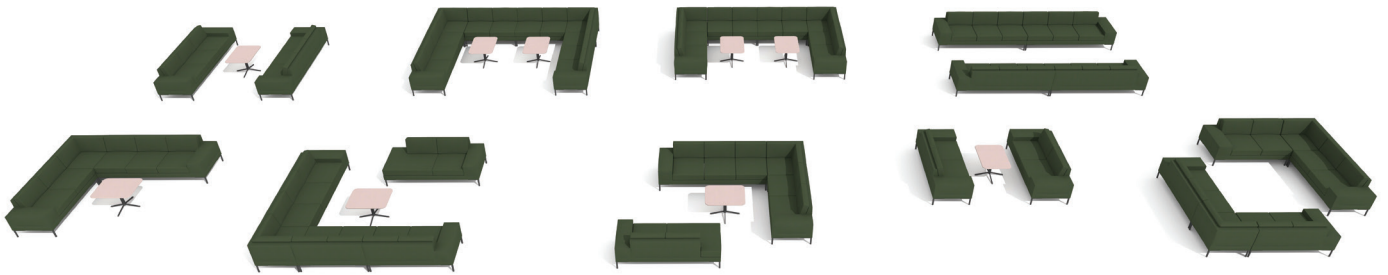

Alfi

Designed by Henry Gurney

Alfi is an elegant wide-armed contemporary sofa system designed for hotel receptions and workplace breakout areas. Created for comfort, the modular design divides spaces to create zones for relaxation.

Features

- Sofa and modular system with 12 pieces
- Black titanium legs
- High density premium quality foam
- Premium quality webbing for optimum comfort
- Power and data options
- Scatter cushions available



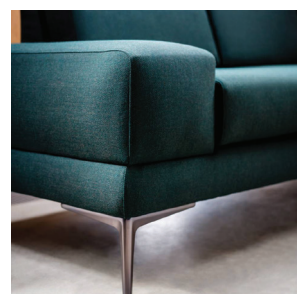

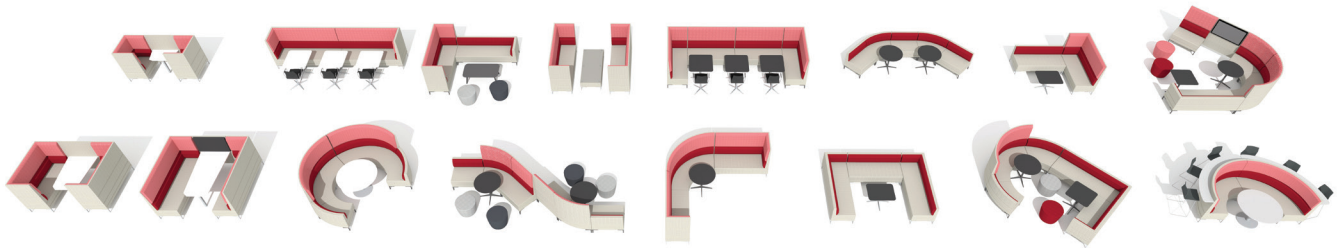

HenRay

Designed by Henry Gurney



HenRay is a sharp and stylish range of soft seating designed for a wide range of environments. High back units offer comfort and privacy and suite perfectly with low back seating, benches and tables. Curved modules and booths complete the extensive collection to create large landscape configurations ideal for meeting and public spaces.

Features

30 straight and curved modular high and low back units

Fully webbed seat for optimum comfort

HenRay Booth options for two, four and six people

Modular units can create large landscapes or small informal meeting areas

Two-tone options

Aluminium, white or black powder coated legs

Booth table units with leg and top options

TV bracket, power and data options

Square scatter cushions and bolsters available

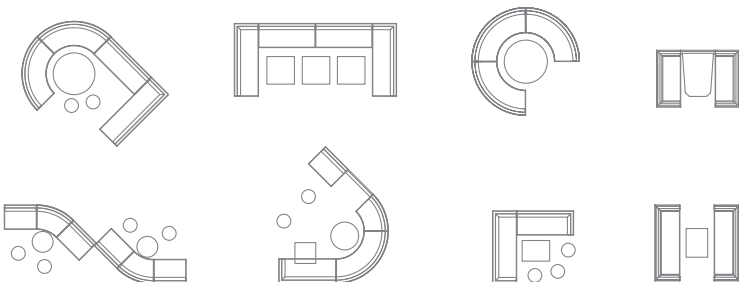





FourUs®

Designed by Anders Nørgaard

FourUs® is everything from a classic sofa to an innovative modular zoning system. A touchdown workplace with the best conditions for interacting, FourUs® provides a space with better acoustic and aesthetic design. The collection includes two and three seater sofas, a booth and a single seater solo unit. The clean Scandinavian design can be showcased in a wide variety of fabric combinations.

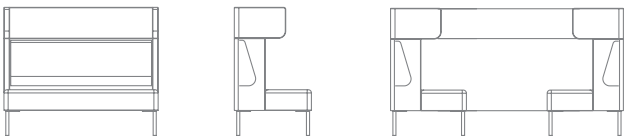

Features

- Modular zoning system
- Freestanding and wall based units
- Four leg and skid frame options available
- Nano laminate 21mm table tops with impact resistant ABS edges
- Range of powder coating colours available
- Optional linking device, castors and wooden legs
- FourUs® Booth incorporates the ingenious pivot table
- Optional shelf in nano laminate for the back of FourUs® freestanding units
- Available with Inno®Tab writing tablet
- Power and data options available
- Square scatter cushions and bolsters available

 Powder coating options detailed in the 2020 price list.



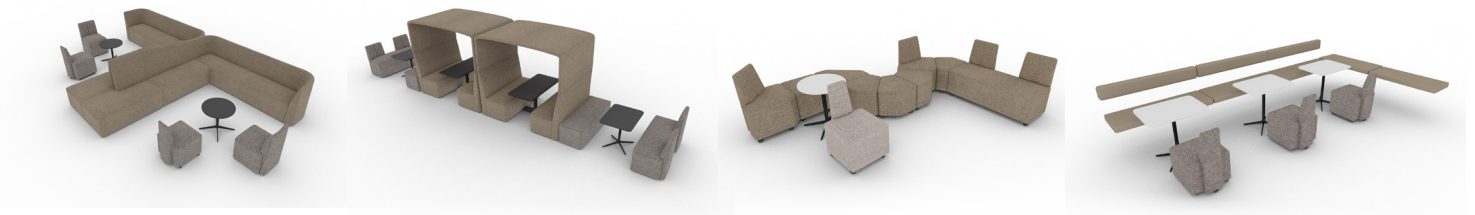

FourLikes®

Designed by Anders Nørgaard

FourLikes® extensive range of modules can be configured and reconfigured to optimise spaces and activate underutilised areas. Although the modules are based on cubes, the ingenious styling creates the perception of curvy and organic shapes. Everything has been considered, from the ideal working seat height to the provision of acoustic and visual privacy.

The FourLikes® Meet offers a private focusing or collaborating space, which can be integrated into larger arrangements of different seating options.

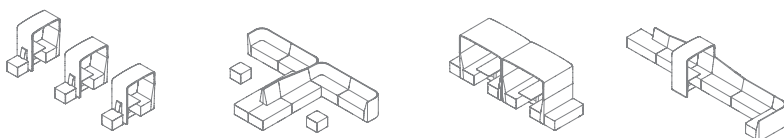

Features

- Modular system
- Compact footprint
- Efficient seating layout
- Ideal working height
- Freestanding scooter with back and castor option
- Private working area with acoustic and visual privacy
- Ingenious styling creates curvy organic shapes
- Power and data options
- Square scatter cushions and bolsters available





FourLikes® Wall Bench

Designed by Anders Nørgaard

The wall-mounted upholstered bench from our FourLikes® family wins you over with its minimalistic look and functional features. It is space saving, maintenance friendly and comes with or without a wall-mounted comfortable backrest. This range enables a higher seating capacity than traditional furniture and is adjustable to your specific needs.

Features

Modular system

Compact footprint

Efficient seating layout

Suitable for dining, meeting and working

Available in various lengths

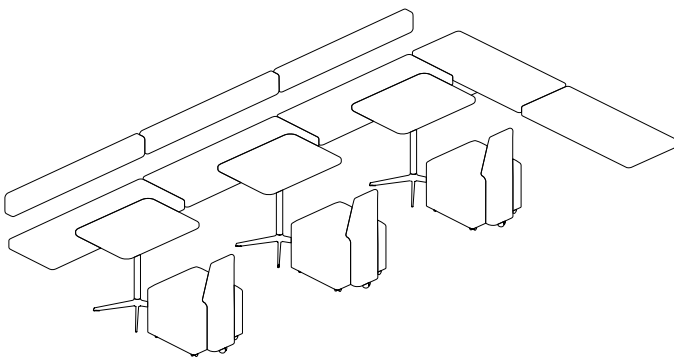





Dishy

Designed by David Fox

The Dishy chair and sofa offer a stylish solution for any corporate or hotel environment. High and low-backed lounge chairs on a variety of bases offer a high level of comfort. The Dishy wood frame also gives this acclaimed design a classic twist. A range of complementary Dishy tables complete the set.

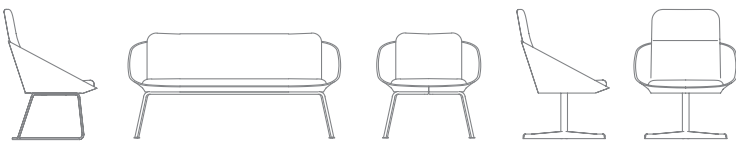

Features

Sofa, high and low back chair

Chrome, powder coated skid or four legged frame

Swivel frame option

Wooden frame in oak finish, other finishes available on request

Powder coating available in a range of colours

Complementary table collection

Two-tone fabric options available

Square scatter cushions and bolsters available





Billo

Designed by Roger Webb Associates

With bags of personality, Billo can match the vibe of a start-up, or create a collaborative space in a more traditional setting. Contrasting twinned stitching adds a crisp detail which can be enhanced by two-tone fabric options.

Features

- Sofa and armchair
- Powder coated and wooden leg options
- Premium quality foam and coiled sprung seat
- Two-tone fabric options
- Twinned stitching detail

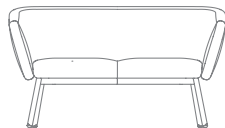





Stretch

Designed by Ian Marchant

With eight individual pieces, Stretch can be a simple armchair or a collection of multiple units. Ideal for relaxation or collaboration, Stretch can be configured to define breakout spaces. Each freestanding piece can be fitted with a range of leg and two-tone fabric options.

Features

Sofa, armchair and modular units

Two-tone fabric options

Powder coated, beech and oak leg options

Fully webbed seat for optimum comfort

Power and data options available

Square scatter cushions and bolsters available

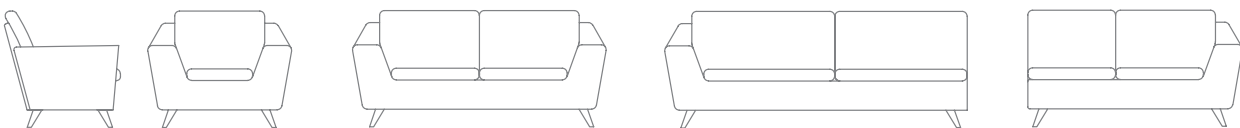

 Powder coating options detailed in the 2020 price list.



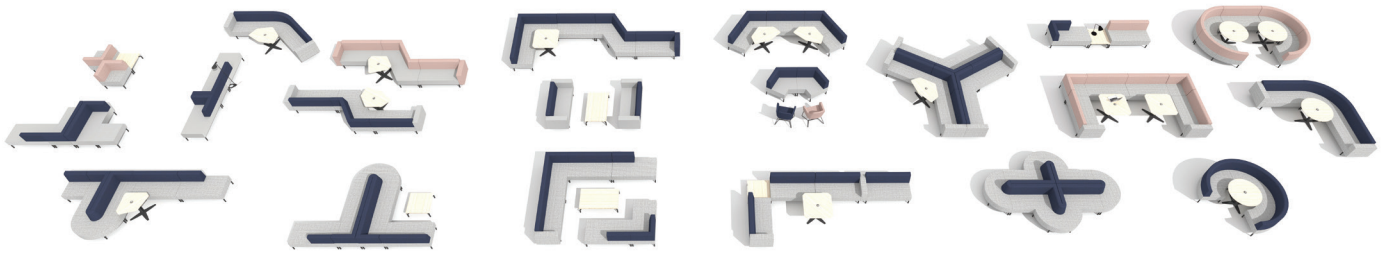

Skyline

Designed by Henry Gurney

Ideal in small or large arrangements, Skyline is perfect for corporate breakout and reception areas as well as more robust educational environments. Recognising that we work in predominantly rectangular spaces, the 22 different modular square and rectangular Skyline pieces allow you to create your own configurations.

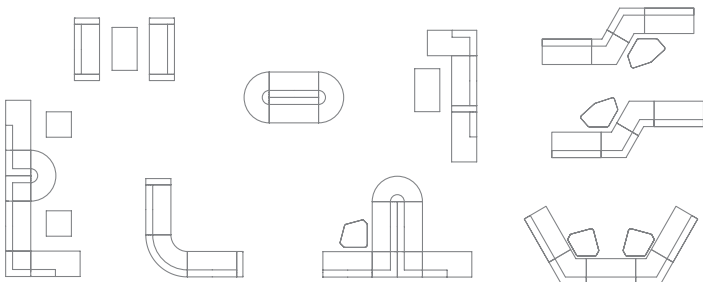

Features

22 modular units for multiple configurations

Matching coffee tables

Two-tone fabric options

Powder coated leg options

Table top options

Split back option available on request

Power and data available

Fully webbed seat for optimum comfort

 Powder coating options detailed in the 2020 price list.



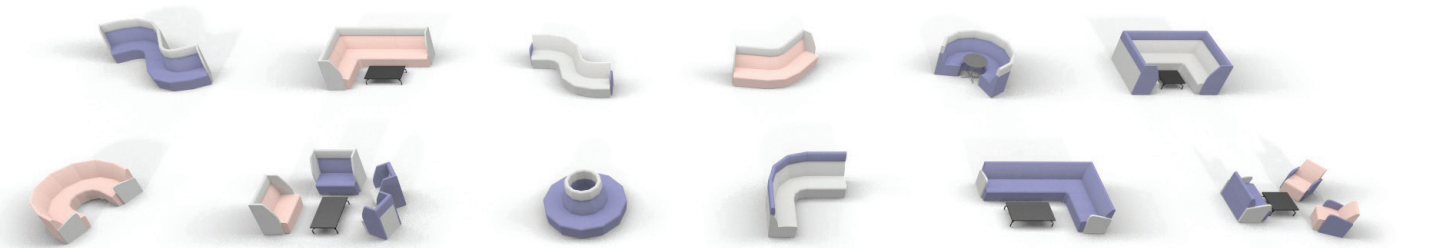

Hilly

Designed by Studio Design

Hilly is perfect for so many places, from schools to waiting rooms, students' unions to office breakout areas, libraries to play zones. It's durable, affordable and flexible. With 22 modular pieces, you can build and reconfigure Hilly to create your ideal layout. There are high and low back options and stand-alone armchairs and sofas. You can add two-tone fabrics and power and data. Tone up the colours for vibrant fun spaces, and cool it down for relaxing, quiet places.

Features

22 modular pieces including straight and curved options

Hilly booth with table

High back and low back options

Armchair and sofa

Extremely durable construction

Two-tone options

Fully webbed seat for optimum comfort

Power and data options

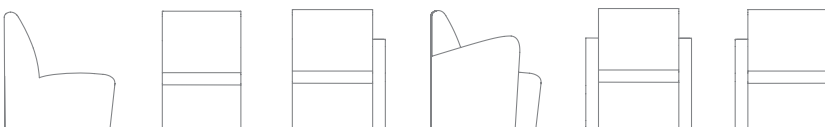





Dorchester

Designed by Studio Ocee

The extremely popular Dorchester range has deep cushions and striking square lines. Dorchester is the ideal choice for a reception, office or breakout area. The armchair and two and three-seater sofas are offered with the option of chrome, oak or black powder coated legs.

Features

Two and three seater sofa and armchair

Available with black or chrome legs

Oak underframe optional

Optional square and bolster scatter cushions

Optional button detail

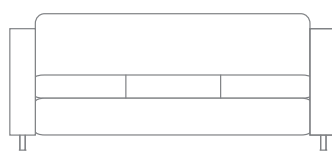
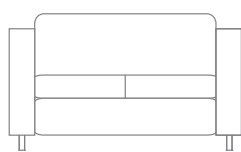
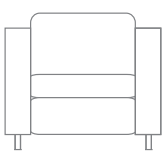
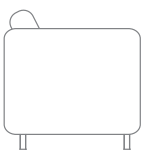



Giggle

Designed by Ian Marchant

Inspired by a smile, Giggle is the perfect style statement for a hotel, reception or breakout area. Giggle can be supplied with a choice of frames and the option of two-tone fabric creates stunning results. The sculpted seat and back offers exceptional support and comfort.

Features

Two-tone fabric option on both seat and back

Powder coating options

Choice of skid, crossover, swivel and swivel return frame options



 Powder coating options detailed in the 2020 price list.



Solace

Designed by Studio Ocee

Combining a generously proportioned seat with a compact overall footprint, Solace is a versatile solution for confined spaces. Exceptionally comfortable, the tub design can be finished with a range of stylish leg options. Striking two-tone fabric options perfectly complement the design.

Features

Compact footprint with generously proportioned seat

Available in two-tone fabric

Standard leg in brushed black or polished chrome and ball foot in brushed chrome

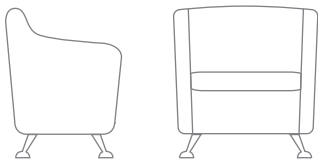



Venus

Designed by Studio Ocee

Venus is an ideal compact tub chair for use in cafés, hotels and other leisure environments. Both the diagonal and the curved frame complement the curvature of the back to create a stylish and practical seating solution.

Features

Two base options

Compact footprint

Two-tone fabric option

Powder coating available in a range of colours

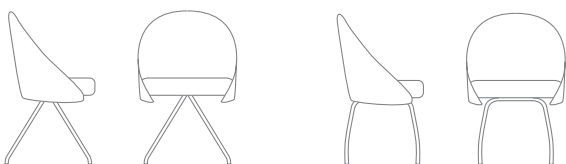

 Powder coating options detailed in the 2020 price list.



Touch

Designed by David Fox

The Touch collection includes simple practical units designed to use space efficiently. Touch benches and connecting tables have thin high tensile steel chrome legs to facilitate the simplicity of the design. The modular design means that Touch looks good as a single bench or as a large configuration to dramatically fill an atrium.

Features

High tensile steel chrome legs

Linking device available

A range of powder coating frame options

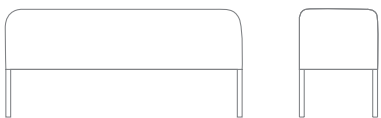

 Powder coating options detailed in the 2020 price list.



Upholstered Stools

Designed by Studio Ocee

Upholstered stools are the stylish accessory for any contemporary reception, touchdown or breakout area. Dot, Dash, Morse, Code and Cube offer a range of shapes, heights, leg and castor options to suit any requirement.

Features

5 variations

Morse and Code with castor option

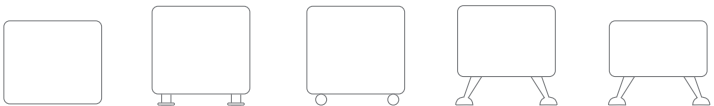



Casino

Designed by Studio Ocee

Casino stools are a great addition to any open space. The option of a single or double crescent enables a multitude of configurations to be created.

Features

3 shapes offered with or without legs

Available with ball foot brushed chrome legs or polished chrome legs

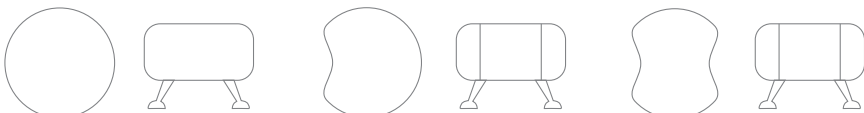

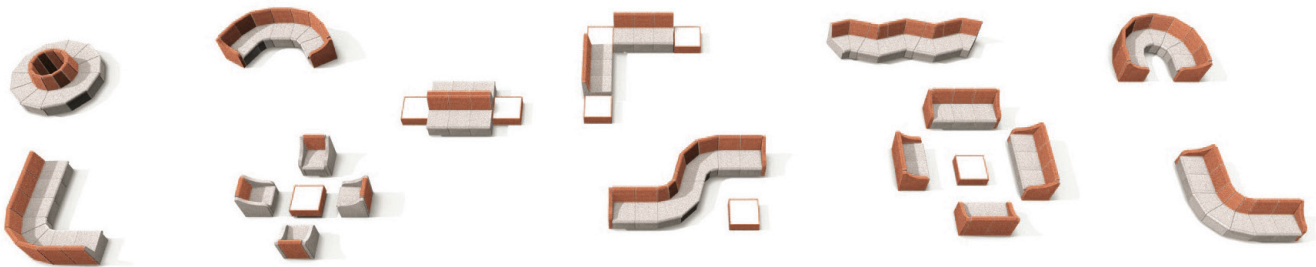

Forum

Designed by Studio Ocee

Forum is a flexible and fully modular seating solution. A matching upholstered table can be supplied with a maple, beech, oak or fabric top.

Features

- Modular units for multiple configurations
- Inner and outer corner units
- Two-tone fabric option
- Maple, beech, oak or upholstered table top options
- Optional square and bolster scatter cushions





The Ernest Race Heritage Collection



Handcrafted in Britain since 1945

UK Price List May 2020



ocee
DESIGN

FOUR
DESIGN

race
FURNITURE

OCEE INTERNATIONAL
GROUP COMPANIES



THE BA3 1945

The BA3 was Ernest Race's first design for Race Furniture. The design was exhibited at the 'Britain Can Make It' exhibition of 1946 and was awarded a gold medal at the Milan Triennale in 1954.

At a time of limited resources, the BA3 manufacturing process was revolutionary; it used salvaged materials, including recast aluminium from redundant aircraft and recycled RAF lightweight cotton duck fabric. Early examples of the BA3 are in the collection of MOMA in New York and the Victoria & Albert Museum in London.



THE ANTELOPE 1950

The Antelope, designed for the 'Festival of Britain', heralded the 'New Elizabethan' spirit with its playful sculptural form. Gordon Russell, chair of the selection judges for the Festival, believed Race's designs were 'miles ahead' of his contemporaries. Painted in the Festival colours of yellow, blue, red or grey, the Antelope became one of the iconic designs of the event.

Today, the Antelope can be used in both indoor and outdoor areas. It remains popular in homes, cafés, restaurants and offices and is also available upholstered.

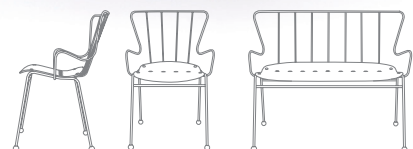

THE ROCKER 1948

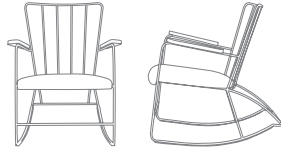

The Rocker preceded the Antelope chair and represented Ernest Race's re-imagining of a classic rocking chair. Though not a fashionable concept at the time, it has become a highly collectable design icon. The Rocker comes with an upholstered seat, wood armrests and optional back cushion.



THE ROEBUCK 1951



Ernest Race's Roebuck was designed as a low-cost stacking chair for café and dining venues.

Now reissued in the original style, with spherical feet, the chair is available in a wood veneer and wide choice of paint finishes.

The Roebuck is still extremely popular in restaurants and hospitality areas where it provides a simple retro look.



There is a separate Ernest Race Heritage Collection brochure and price list available. Full product details are also shown on our website www.oceedesign.com

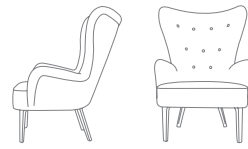

THE DA 1946

The DA, launched in 1946, was Ernest Race's interpretation of the classic wingback chair. This was upholstered furniture for the modern, space conscious home. The range was originally conceived in collaboration with Heals of London.

With its light anatomical construction, the DA series was a radical departure from the traditional bulky armchairs of the past, while still providing exceptional comfort. The 1951 Race catalogue reinforced Ernest Race's philosophy stating that, 'Bulk and weight are not synonymous with comfort.'

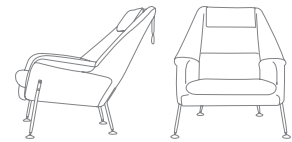

THE HERON 1955

Ernest Race continued to investigate new manufacturing processes with the Flamingo and Heron chairs. The Heron differs from the Flamingo in the position of the legs and the addition of a loose head cushion and loose seat cushion.

Both chairs fuse exceptional comfort with a dynamic sculptural form and are contemporary with similar designs by Eames and Saarinen. The design incorporates technically challenging upholstery techniques, still in use today. The iconic look is finished with the addition of the Ottoman footstool.





THE FLAMINGO 1957

Ernest Race preferred the Flamingo to the Heron; it differed in the position of the legs and offered fixed cushions more suitable to commercial settings.

The Flamingo won a Design Centre Award in 1959 due to its skilful use of modern materials.

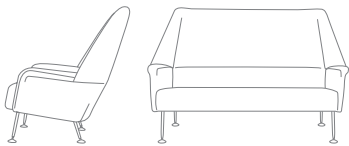

BA TABLE 1955



GAZELLE TABLE 1951

Ernest Race designed the Gazelle table for the 1951 'Festival of Britain' to complement the Antelope chairs. With the same steel rod frame and ball feet, the Gazelle is also a perfect partner to the Roebuck chair. The table and Race's Unicorn three-legged chair were also exhibited at the Brussels World Fair in 1958.

Ernest Race designed the BA tables using the same style of recast aluminium legs as the BA3 chairs. The BA table's light appearance contrasted with traditional heavier furniture and answered the requirement for lighter pieces, which could create a sense of space and be easily moved.





Workspaces & Landscape

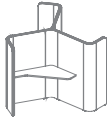

Den 52



FourUs Wall 56



Hotbox 57

Den.

Den is your noise barrier, acoustically enhanced to separate you from the hubbub of the workplace. Den can have power, reading lights and data connectivity. Worktops can be positioned to suit your working style, and soft seating can make your Den a comfortable retreat.

Unique Economical Construction

Den's unique junction system enables numerous configurations to be constructed with shared components, unlike other acoustic work systems which extend their configurations by placing stand-alone units back-to-back. Den's modular design ensures an economical construction, which can be easily extended and reconfigured to suit your changing needs.

Acoustics

Den is an acoustically enhanced product designed to reduce noise and distractions. The acoustic performance of the panel construction has been independently tested in an acoustics research laboratory following the guidelines found in BS EN ISO 354:2003 (Acoustics - Measurement of sound absorption in a reverberation room).

Accessories

A range of accessories and additional soft seating, designed by Will Hudson, offer further agile working options.

Features

8 styles with an array of accessories

Acoustic panels

Unique junction system with shared components for economical construction

Designed to allow numerous configurations and reconfigurations including bespoke specials

Plain and quilted fabrics

Silver, black, white and oak trim line

Worktops in a variety of finishes with a matching or contrasting edge

Worktop sizes of 43mm, 25mm and chamfered 12mm

Soft seating options

Full selection of lighting, power and connectivity options

Electrically operated sit/stand desk available in the Den Booth with Link push button control

Den canopy with light available on Den Diner and Den Booth

Tested in accordance to BS EN ISO 354:2003

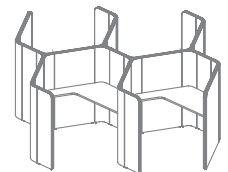
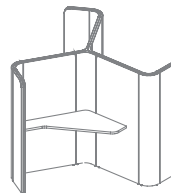
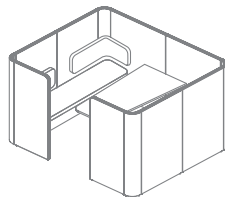
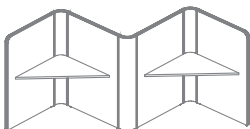
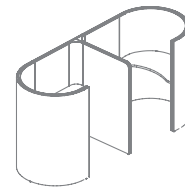
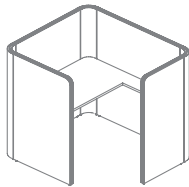





Den.ZigZag



Den.Spoke



Den.Honeycomb



Product: Den Cube. (Custom configuration)



FourUs® Wall

Designed by Anders Nørgaard

FourUs® Wall gives you the opportunity to exploit every square foot of space by creating work areas on underutilised walls. FourUs® Wall is the perfect solution for a touchdown work area.

Features

Wall based units

Nano laminate 21mm table tops with impact resistant ABS edges



Note. Stock to order



Hotbox 2



Hotbox 1



Hotbox 2



Hotbox 3

Hotbox®

Hotbox lets you personalise and define your space, wherever you choose to work. It makes agile working easy as you move freely around the office. From locker to hot-desk to co-working space - just gather your tools and go.

Be more organised so you feel engaged and productive with all your things close to hand.

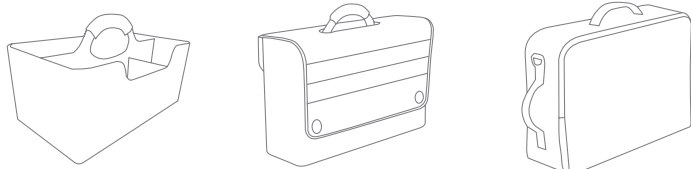

Features

Personalise

Make your workspace your own so you feel at home wherever you choose to work.

Organise

With everything close to hand you'll feel more comfortable, organised and productive.

Easy

Want to work in a new space or with a new team? Easy, just gather your things and go.

Move

Take the hassle out of moving your things from your locker to your workspace.





Meeting, Conference & Café Seating



FourMe® 64



FourSure® 66



FourCast® 68



Ecolabel Chairs 72



Four® Outdoors 73



**Four®Seat
Benches/Stools** 74



Panache 76



**Absolute
Meeting and
Work Lite** 77



**Era Meeting
and Work Lite** 78



Alina 79

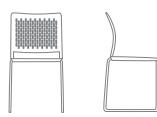

Patch 80



Volee 81

The Four® Family

The Four® Family is a concept as well as a product collection – a new way to work and interact. Designed by architects Christina Strand and Niels Hvass, the Four® seating range is characterised by superb functionality and a minimalistic Scandinavian design.

FourCast®, **FourSure®** and **FourMe®** combine a distinctly Scandinavian design signature, with a range of base styles to create a consistent and harmonious look throughout a building. We have considered every seating application, for the education, hospitality and business sectors to create the perfect chairs for every environment.

The ingenious designs embrace the shift away from traditional interiors towards areas that encompass the latest technology and enhance the best working practice. Accessories such as the ingenious **Inno®Tab** create the perfect agile working platform by accommodating phones and computer tablets.

Always striving for the highest environmental standards, our **Four®** chairs are 100% recyclable and tested to the highest quality standards, making them suitable for the toughest environments. We are extremely proud that our **Four®Sure** chairs have received the European Ecolabel accreditation.



FourMe®



FourSure®



FourCast®



FourMe®



FourSure®



FourCast®



FourMe®

Designed by Strand and Hvass

The elegant Four®Me armchair is offered on seven different base options and is designed to bring a warmer, more domestic feel to public spaces. The soft grip surface of the shell consists of a bio-composite polypropylene material reinforced with wood fibres, making every chair unique and a very different tactile experience in comparison to other typical shell chairs.

Features

Bio-polypropylene shell

7 different base options

Shells available in 4 colours

A range of powder coated frame options

Non-upholstered, seat pad, inner and fully upholstered options



 Powder coating options detailed in the 2020 price list.





FourSure®

Designed by Strand and Hvass

FourSure® has a more rounded shape than the FourCast® chairs but offers the same variety of shells and bases. Accessories include the ingenious Inno®Tab writing tablet, that incorporates a cup holder and dashboard for tablet or phone.

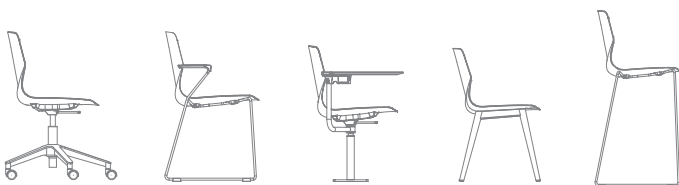

Features

9 shell colours

8 base types including a wooden leg option

Inner upholstery, seat pad and non-upholstered options

A range of powder coated frame options

Range of accessories, including the ingenious Inno®Tab tablet

Compatible with the Four® chair suspension system

Auditorium version

Stacking options

Available fully upholstered





FourCast®

Designed by Strand and Hvass

The FourCast® offers a common seat shell design, which is available on different bases to create a consistent look throughout a building, whether in the canteen, classroom, conference or boardroom. We have considered every seating application, both for the education and business sectors.



Features

Shells available in 9 colours and wood veneer options

11 base styles including a wooden option

Non-upholstered, seat pad and fully upholstered options

A range of powder coated frame options

Range of accessories including the ingenious Inno®Tab folding tablet

Compatible with the Four® chair suspension system

Auditorium version

Stacking options

 Powder coating options detailed in the 2020 price list.









Ecolabel Chairs

Designed by Strand and Hvass



The objective of the EU Ecolabel is to reduce the overall environmental impact from production and consumption of goods. The entire life cycle of our Eco chair, from raw material to the finished product through to disposal and recycling has been included in the assessment.

Features

FourSure® 44, FourSure® 90, FourSure® 88 and FourSure® 105 FourCast® Four, FourCast® Counter, FourCast® Line and FourCast®

Matched table height 74 cm, 90 cm/105 cm

Stackable

Polyamide glides as standard

EN 16139 L2, Ansi / Bifma / GS



 Powder coating options detailed in the 2020 price list.



Four® Outdoors

Designed by Strand and Hvass

Our outdoor seating and table solutions fully accommodate users' needs for a place to dine 'al fresco'. Take full advantage of the scenery and choose shell colours that complement your outdoor surroundings.

Features

Outdoor use for temperatures down to - 50°

Screws and brackets made from stainless steel

Frames powder lacquered and surface treated in accordance with ISO 7253 corrosion C4

Stackable

Outdoor tables available. Price and lead time available on application



 Powder coating options detailed in the 2019 price list.



Four® Seat Benches & Stools

Designed by Strand and Hvass

The Four® Seat Bench and Four® Stool collections are perfect for creating a mix of seating styles. Created with bent oak seats, the stools and benches are available with oak or steel legs and a range of upholstery options. The stools are available at three different heights.

Features

Available in oak with a seat pad, upholstered or non-upholstered options

Available with oak legs or steel legs

Steel legs and the crossbar are available in a range of powder coating colours

3 bench lengths are available

Stools in three heights

Black oak stained finish option



 Powder coating options detailed in the 2020 price list.





Panache

The Italian designed Panache is a chrome frame stackable chair ideal for visitor, meeting and conference room use. Panache is available with a full or three quarter upholstered back.

Features

Upholstered full and three quarter back options

Chrome frame

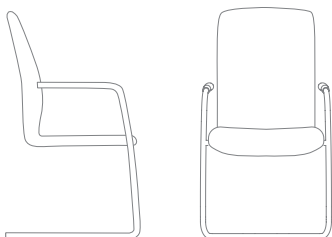



Absolute Meeting & Work Lite

Complementing the task chair, the Absolute meeting and Work Lite chairs are provided with a range of base options and an upholstered or mesh back.

For details of the Absolute Task chairs see page 118.

Features

Black and white frame options

Cantilever frame and 4 star base with chrome finish

Upholstered back with 100% recycled polypropylene cut-out

Mesh back

Matches the Absolute task chairs

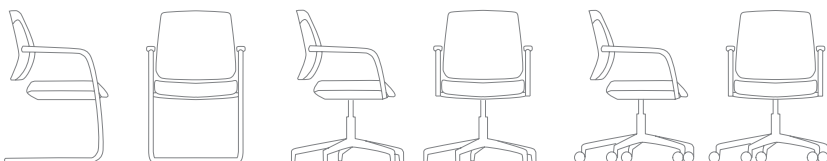



Era Meeting & Work Lite

Era facilitates all styles of working. Mesh, upholstered and upholstered with a rear panel back are available on cantilever, swivel and 4 legged bases. The range complements the Era task chairs.

For details of the Era Task chairs see page 119.

Features

Black and grey frame options

Mesh, upholstered and upholstered with solid rear panel

Arm and non-arm options

Matches the Era Task chairs





Alina

The extensive Alina range is ideal for the training, meeting or conference room. An upholstered seat and mesh back is available on three stackable frame options.

Features

Upholstered and mesh back options

A wide range of frame styles

Writing tablet options

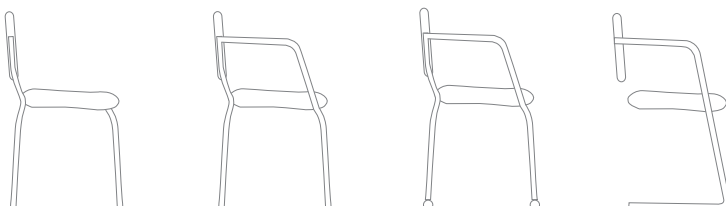



Patch

Patch is Ocee's exclusive polypropylene chair with a wider more comfortable back. Patch is available with a skid or 4 legged polished chrome frame and optional upholstered seat.

Features

Polypropylene seat

Upholstered seat option in a variety of fabrics

Arm & writing tablet options available
(price and lead time on request)

Linking device available for conference use

Trolley available

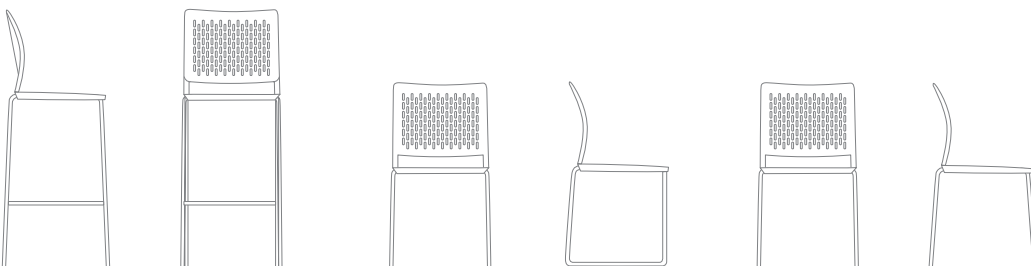



Volee

Volee can be supplied as a single chair or as a modular two, three and four seat option. The single chair is ideal for conference and meeting areas. With the addition of a table section, the Volee modular system is ideal for all waiting room environments.

Features

One, two, three and four seat options

Optional table section

Floor fixing bracket available

Optional chrome arm

Single arm or non-arm chair option available

Writing tablet option

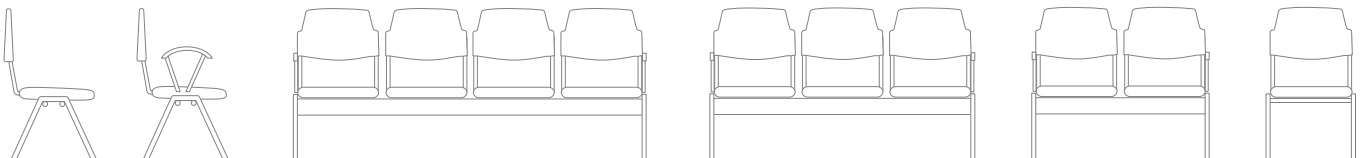







Table Collection



Kite® 86



FourMat® 88

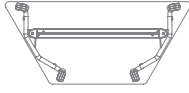

FourFold™ 90



FourReal® A 94



FourReal® A XL 96



FourReal® Flake 98



FourReal® Wood 100



**FourReal®
741, 74, 90 &
105 with
partitions** 102



Four® Tables 104



**Buddy
Power Tables** 108



Noah Tables 109



**Harc Rectangular
Tables** 110

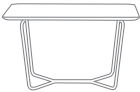

Harc Tub Tables 111



Dishy Tables 112



Giggle Tables 113



Chai 114



Mocha 114



Kite®

With the Kite® table system everyone has a good line of sight and sits at a defined straight edge with 750mm of personal space; no one straddles a table leg, writes over a seam or is squashed into a corner. The four sided frame provides greater rigidity and durability than traditional I frame centrally supported tables.

The dual-locking castor limits movement, negates the need for linking devices and makes Kite® as stable as fixed-frame furniture.

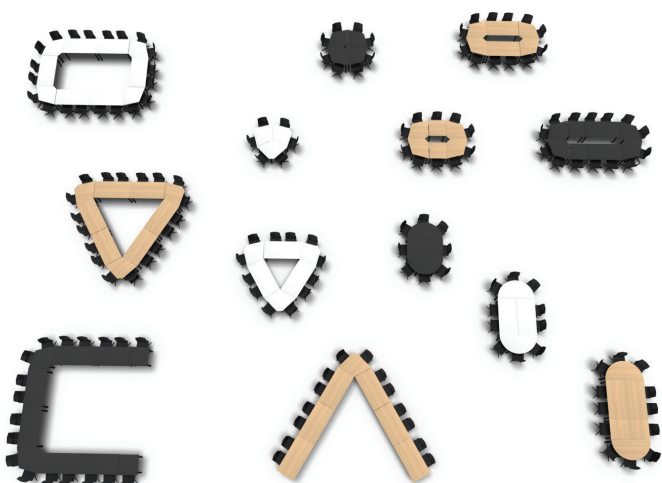

 Powder coating options detailed in the 2020 price list.

Features

Unique Kite® shape creates the perfect configuration for any presentation style

Quickly assembled and reconfigured by a single person

Easy to fold, move and store without heavy lifting or the need of a trolley

As stable as fixed-frame furniture with a rigid and durable 4 sided frame

Locked castor prevents the need for linking devices

50mm levelling ensures table-tops meet flush

Narrow transit profile fits easily through doors (390mm max)

Modesty panels and cable management can be fitted without compromising folding function

Compact nesting to maximise space

25mm MFC tops available in a variety of finishes

MFC, with banded and inlay tops

Straight and tapered legs

Kite Shape and Kite Rectangular folding tables tested to BS EN 15372:2008 - Test Level 2

In table power and data options

Credenza's in matching finishes available





FourMat®

An elegant conference table with an aluminium T-frame, which is available as a single or modular table.

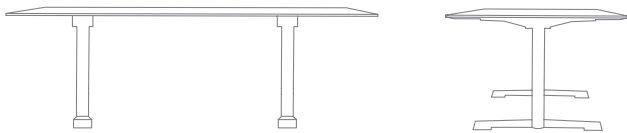

Features

Tops with knife edge detail, available in a range of finishes

T-Frame in aluminium (56mm diameter x 3mm / 70mm diameter x 1.5mm)

Optional electric motorised height adjustment from 675mm to 1095mm

Optional cable duct, single or double

Optional power socket, 4 or 8 pieces, 240V with 5-metre cable





FourFold™

Designed by Julian Evans & Broome Jenkins

Comprised of equal parts, timeless design and smart engineering, FourFold™ 4 legged flip-top table provides a super intuitive and highly stable table solution. With an intuitive design that makes the table easy to move, the room layout can be changed easily to meet the requirements of different applications. The tables can also be nested for storage to utilise space effectively.

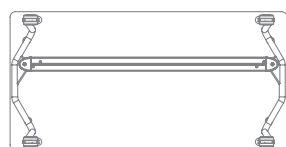
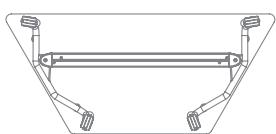

Features

- 4 legged flip-top table
- Strong and stable
- Slanted legs
- Optional castors with roll and turning-lock
- Optional power grommets and troughs for power and wire management
- Heavy duty construction for high use spaces
- Click-lock flip-top (when in use)
- Duo-motion flip-up mechanism
- Compact nesting = space saving
- Easy to manoeuvre

 Powder coating options detailed in the 2020 price list.



Four® Table Family



The Four® table range is created with our requirement for function, design and Aha! There are those clever touches that make life easier, whether it is integral castors for simple movement, or seat suspension to lift chairs off the floor for cleaning.

The family includes A-Frames, multifunctional folding and non-folding tables and Room-in-Room partitions for privacy.

Power and data, table top finishes and a range of powder coating options are available on every table.



FourReal® A/AXL



Frame



FourReal® Flake



FourReal® Wood



FourReal®



FourReal® Eating



FourReal® Standing





FourReal® A

Designed by Studio Ocee

FourReal®A is a clever, multi-purpose space saving solution for all types of environments. The FourReal®A table is the perfect platform for collaborating, socialising, learning and focusing. By using the A-frame to hang lighting, plants, or your own accessories, you can create an attractive, comfortable and inspirational space for dining, collaborating or solo work.

Features

Legs: D32 x 2.5 mm, S235 steel, EN 10305-3 F300C

Rail: Aluminium EN AW-6063 T

2 integrated castors PUR/PA6

For 6-8 people

Top shelves available

Range of other table tops and finishes available on request

Chair suspension available

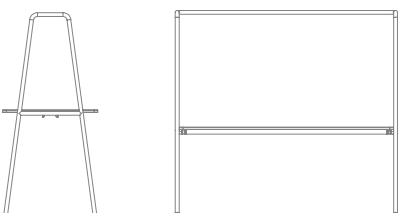

 Powder coating options detailed in the 2020 price list.

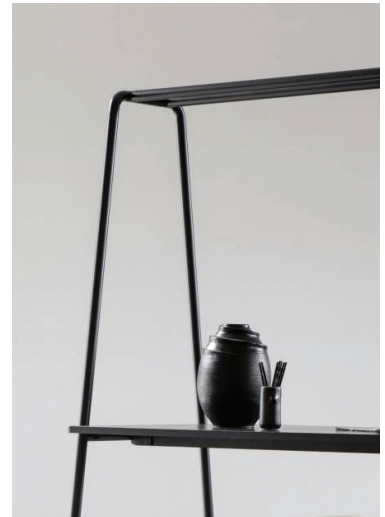



FourReal® A XL

Designed by Studio Ocee

FourReal® A XL is a real conversation starter. This table is the perfect fit for collaborative work or head-down work. It works excellent as a communal area, for eating, or meetings. The new larger dimensions mean room for more. More people, more paperwork and computers. The new dimensions do not compromise quality. This table is still durable, mobile and solid. We've added a simple extension pack to the FourReal® A XL end frame, enabling quick changes to the layout of the room, by adding more tables. And room for even more people. Add a little light or biophilia for personalisation.

Features

Legs: D32 x 2.5 mm, S235 steel, EN 10305-3 F300C

Rail: Aluminium EN AW-6063 T

2 integrated castors PUR/PA6

For 6-8 people

Top shelves available

Range of other table tops and finishes available on request

Chair suspension available

FourReal A XL Extensions available

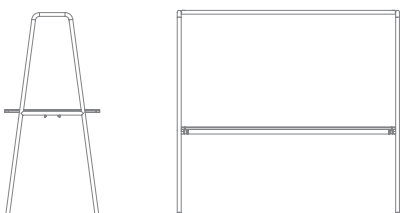

 Powder coating options detailed in the 2020 price list.





FourReal® Flake

Designed by Anders Nørgaard

FourReal® Flake is a range of multifunctional folding tables with integrated castors for easy handling by one person. The tables are designed to be combined across variations of shapes and sizes and optional extras can be added to solve specific needs in the versatile canteen or open space layout. Choose between various colours and optional extras.

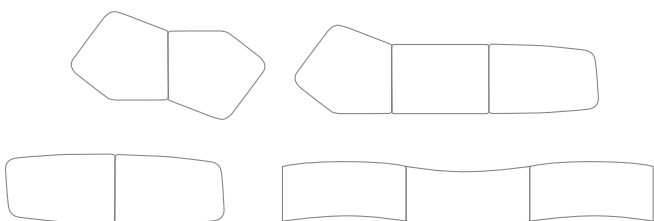

Features

Table height 74 cm

Matching ABS edges

Room-in-room options

Integrated castors on two legs

With height adjustment glides on the other two legs to aid movement

Foldable by one person without the use of tools

Chair suspension

Wide range of powder coating colour options

Power and data available

 Powder coating options detailed in the 2020 price list.





FourReal® Wood

Designed by Strand & Hvass

The FourReal® Wood is new to the already popular FourReal® collection. The folding table with oak legs is a multifunctional table available in 74 and 90 heights. Optional extras can be added to solve specific needs in canteen or open plan layouts.

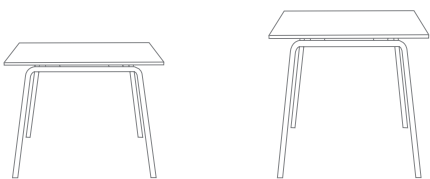

Features

Tables are foldable without the use of tools

Four different top sizes

Available with oak legs or optional black stain

Range of table top finishes

Available in 2 heights, 74 and 90

Power and data options





FourReal® 741, 74, 90 & 105 with partitions

Designed by Studio Ocee

FourReal® is a folding table designed to be used on its own or with the partition; the rounded shape perfectly complements the Four® seating ranges. By simply clipping the FourReal® Room-in-room partition to the FourReal® table you create small intimate work areas in larger rooms. The clever design allows one person to quickly create a workspace with improved acoustics and a sense of privacy.

Features

Matching the FourSure®, FourMe® and FourCast® family

4 legged frame made of 32mm diameter steel tube

Integrated castors on two legs to aid movement

Easily folded by one person without the use of tools

Optional chair suspension and cable duct

Table ready prepared for FourReal partitions

Other table sizes, veneer, laminate and nano laminates, edging choices or outdoor options are available on request

Power and data options



 Powder coating options detailed in the 2020 price list.



FourReal® 105



FourReal® 74 Round



FourReal® 74

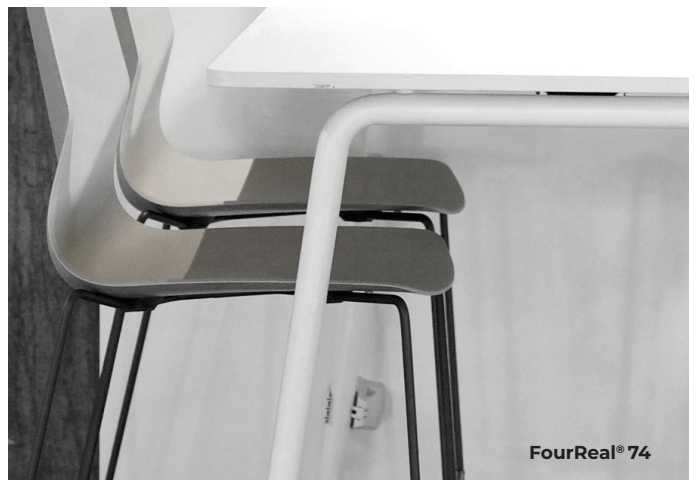

FourReal® 74



Four® Eating, Standing, Counter & Resting

Designed by Studio Ocee

Our collection of extremely stable high and low tables are available in a range of finishes. Four®Eating, Four®Standing and Four®Counter all have integrated castors on two legs to aid movement.

Four®Resting tables are a versatile range of occasional table at a variety of heights.

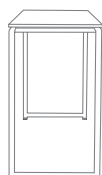

Features

High, low and occasional tables in a variety of sizes

Folding options

Four®Eating, Four®Standing and Four®Counter with integral castors on two legs for easy movement

Four®Resting with chamfered table top on 4 or 5 star bases

Wide selection of table top and frame colour options

Chair suspension options

Power and data available

 Powder coating options detailed in the 2020 price list.



Four®Resting



Four®Standing

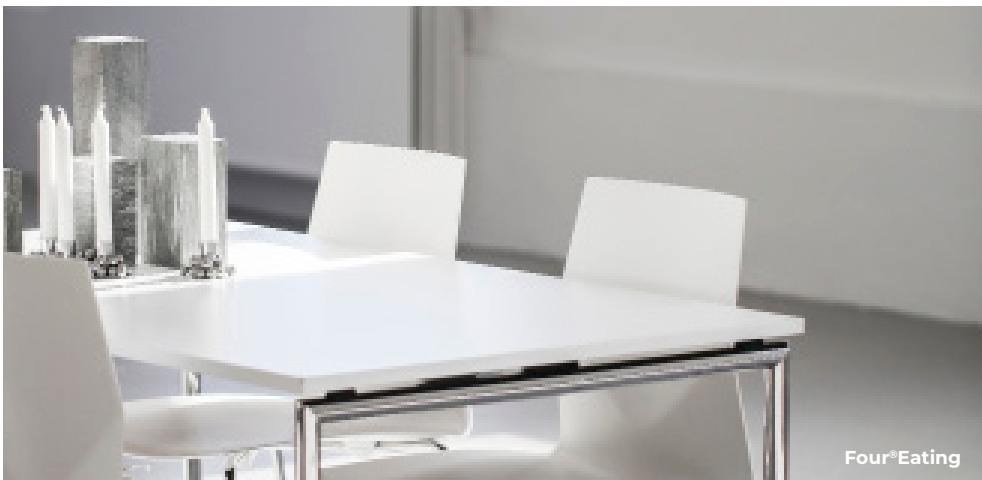

Four®Eating





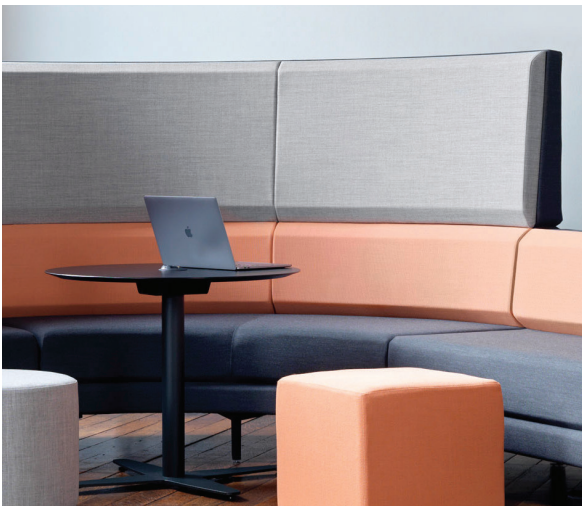

Buddy Power Tables

Designed by Henry Gurney

'Buddy up' with the perfect table for your working style by choosing the Buddy Power Table collection from Henry Gurney.

Special top shapes and table heights have been designed to complement Ocee's extensive modular seating offering, including Skyline, HenRay and the Hilly collection. Dining and poseur height tables complete the collection to offer a full suite of integrated power tables.

It is simple to power up with the Buddy Tables' elegant integrated cable management system. The central column and prepared 80 mm hole offers the ability to add power to all table heights and sizes.

There are three heights, six tops, power, data and colour options all designed to enable you to create your perfect working Buddy.

Features

Central column provides clean cable management system

Prepared central 80mm hole to accept power and data units

Three height options: soft seating height, dining height, and poseur height

Four table top shapes available with a selection of sizes

Metal plate four star base

18mm MFMDf top with chamfered edge detail

Feet to allow cables clear access beneath the base

A wide of range of table top and powder coating options

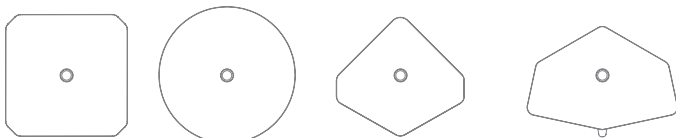

 Powder coating options detailed in the 2020 price list.



Noah tables

Designed by Samuel Wright

Although designed to complement the Noah seating range, this stylish solid wooden table is an ideal companion for many of the Ocee ranges.

Features

Matches the Noah rocker, armchair and sofa

Options in solid oak and black ash wooden frames

Other wood options on application

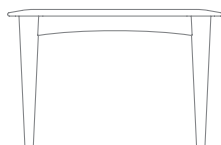
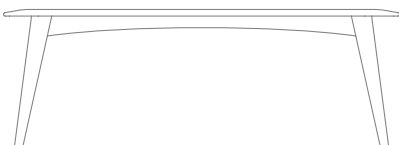



Harc

Rectangular Tables

Designed by Roger Webb Associates

Harc rectangular tables are designed to complement the Harc chair, sofa and tub chair collection.

Features

Chrome, powder coated, or solid wood leg options

Wooden table tops

MDF chamfered table tops in a variety of finishes

Cast aluminium powder coated legs in a range of colours



 Powder coating options detailed in the 2020 price list.



Harc

Tub Tables

Designed by Roger Webb Associates

The extensive range of Harc Tub tables suite perfectly with the Harc Tub chair collection.

Features

Chrome or powder coated skid frame, polished aluminium 4 star and wooden leg options

Range of table top finishes and powder coating options available

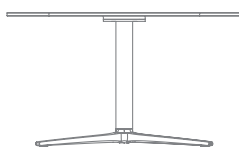
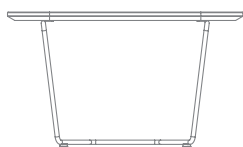
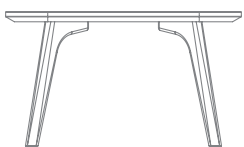

 Powder coating options detailed in the 2020 price list.



Dishy Tables

Designed by David Fox

Dishy coffee tables are created to complement the Dishy seating range.

Features

- 18mm melamine faced MDF top with chamfered edge
- Range of top and powder coating finishes

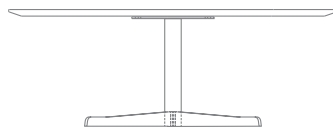
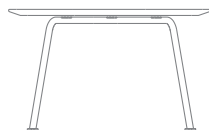
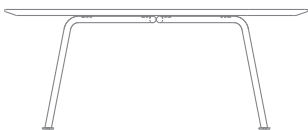

 Powder coating options detailed in the 2020 price list.



Giggle Table

The Giggle crossover skid frame table matches the Giggle seating collection and can be powder coated in a range of colours.

Features

Table laminated 18mm MFMDf with chamfered edge

Chrome or powder coated crossover skid frame

 Powder coating options detailed in the 2020 price list.



Chai



Mocha

Chai & Mocha

Chai and Mocha are ideal for all types of breakout environments. Chai has a square base and top and Mocha has a round base and top.

Features

25mm MFC tops with straight edge

Black or chrome frame

Range of top finishes

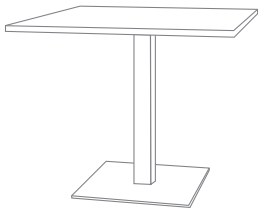

 Powder coating options detailed in the 2020 price list.



Our Acoustic Collection

For many years we have been promoting the benefits of good acoustics. We have worked with leading acoustic experts to produce a highly effective acoustic portfolio. A good acoustic environment can improve effective interaction, create a positive setting and aid wellbeing.

Acoustic properties of our products

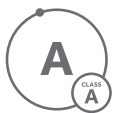

Absorb



Block



Cover



Divide



Reverberation Control



Speech Privacy



Visual Privacy



Ocee Acoustics

Throughout any space, be it single or multi-use, no matter what size or purpose, there are acoustic factors that need to be controlled to maximise wellness and productivity. With a product portfolio acknowledging the ABCD of acoustics, Ocee has an acoustic solution for all types of working environments.

We have created a highly effective acoustic solution portfolio with colour and finish options to facilitate a full interior design palette.



Absorb



Block



Cover



Divide



Reverberation
Control



Speech
Privacy



Visual
Privacy



Positive Sound

- Fully tested acoustic collection
- Wall and ceiling mounted options
- Features Tessellate shapes, Dot, Fabricks™ and Puzzle
- Created by leading designers and acousticians
- An easy to specify acoustic collection
- Highly recyclable
- Simple to specify, simple to install
- Available in an extensive fabric selection



Snowsound® Technology

- Visibly distinctive or discreet acoustic solutions
- Freestanding, wall and ceiling fixed options
- Extensive range of panel shapes
- Class A absorption and optimum acoustic performance
- Fully independently tested
- CE mark
- Greenguard Gold for LEED rating





Task Seating



Absolute 120



Era 121



Airo 121



Harvey 121



Sphere 122



Flexion 122



Poise 122



Re-act Deluxe 123



Re-act 123



Re-act Mesh 123



Fusion 124



Tick 124



Urban 124



Goal 125



Industrial 125

Absolute Mesh

Absolute is ergonomically designed for maximum comfort. The mesh and upholstered task chairs are offered with a range of options to suit individual needs. The Mesh back can be selected in eight colours and includes an integral lumbar.

For details of the Absolute Meeting and Work Lite chairs see page 77.



Absolute Upholstered

Absolute has a distinctive curved back and stylish detailing. The upholstered version has a solid outer back.



Absolute White

Absolute White is offered in both mesh and upholstered back, with the full range of Absolute options.

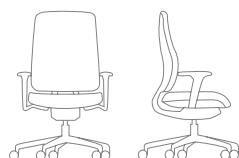

Era

Era has 24 different chair options to facilitate all styles of working. Mesh, upholstered and upholstered with a rear panel back are available on task, cantilever, swivel and 4 legged bases.

For details of the Meeting and Work Lite chairs see page 78.



Airo

Airo is an extremely comfortable high back task chair with a breathable mesh back. Airo is standard with a synchro mechanism and integral seat slide.



Harvey

With petite, standard and tall options, Harvey is designed to accommodate individuals of different sizes whilst maintaining a consistent look throughout the working environment.



Sphere

Fully adjustable with an ergonomically moulded seat and back, Sphere is the choice for 24/7 applications. Two mechanism options are offered as well as a heavy-duty version. A cantilever visitor chair is also available.



Flexion

The popular Flexion is available in three sizes and includes an ergonomic headrest and mechanism options.



Poise

With a waterfall seat front and a comprehensive range of ergonomic features, Poise has been specifically developed to relieve leg and back pressure. A synchro mechanism with seat slide is standard. A cantilever meeting chair is also available.



Re-act Deluxe

The Re-act Deluxe is a supportive chair with great adjustability and is available with specialist adaptations such as seat air, headrest and coccyx cut-out for enhanced comfort. The Re-act Deluxe is suited to larger/taller users due to its deep seat and large backrest. A cantilver visitor chair is also available.



Re-act

One of our best selling products, the Re-act sets the benchmark for reliable, affordable and comfortable operator chairs. Height adjustment, ratchet back and tension control make the range fully adjustable. A cantilver visitor chair is also available.



Re-act Mesh

The Re-act Mesh is the new addition to the extremely comfortable and highly adjustable Re-act range with all the expected Re-act features, Re-act Mesh is a great addition to the range.



Fusion

With petite, standard and heavy-duty options, Fusion is designed to accommodate individual users while maintaining a consistent look throughout the office. Fusion has three mechanism options and a matching cantilever visitor chair.



Tick

The popular Tick has a comfortable oval shaped moulded cut foam seat and back. Tick is fully adjustable and can be supplied with a choice of five star or cantilever bases and additional ergonomic options. A matching cantilever visitor chair is available.



Urban

With its bulb shaped back and generous size seat, Urban offers a high level of comfort and style. Multi-functional mechanisms, ratchet back and tension control allow the chair to be quickly adjusted to suit individual users. A matching cantilever visitor chair is available.



Goal

A proven, affordable, entry-level chair with enduring popularity, the Goal has performed perfectly in thousands of environments. A mesh back and upholstered back with a durable plastic back cover option and a cantilever visitor chair are available.



Technician

Fully adjustable operator chair with taller gas lift for use with higher workbenches.

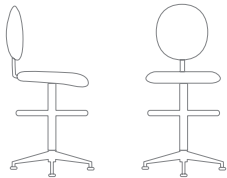

Dublin

Designed for industrial and laboratory use, the Dublin has an easy-clean fluid resistant seat and gas lift height adjustment.

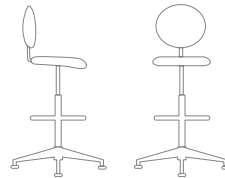

Derry

Derry is a solid polyurethane stool designed to withstand the hardest factory, warehouse or laboratory environments.



Re-act Draughtsman

Designed for use with higher workstations, the Re-act Draughtsman is fully adjustable and extremely comfortable.

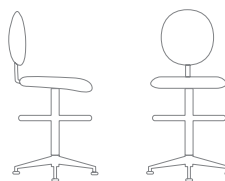

Powder coating options

The options for powder coating are specified on each product page entry. The standard options for products vary. Surcharges may apply.

RAL Frame Colours

Standard

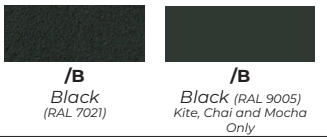

Optional - Metallic

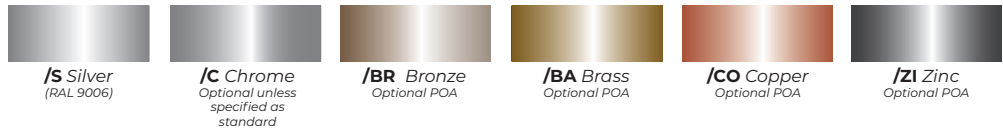

Optional - Primary



Optional - Pastel

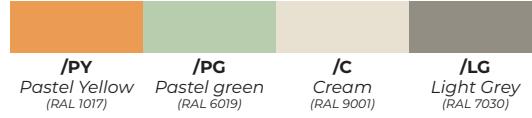

* Additional charges and longer lead times may apply for non standard finish options

Optional - Monochrome



Table Tops

We offer a range of table tops on many of our tables. The full details are specified on each product page. In addition to the ranges specified below we can offer Formica colour, and Formica pattern finishes. Please contact us for more details.

Band 1 - Standard Finishes

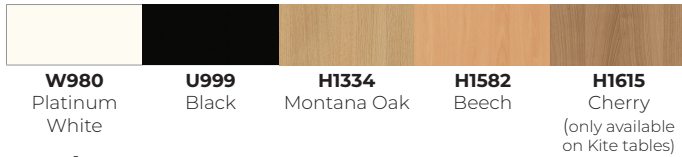

Band 2



Band 3

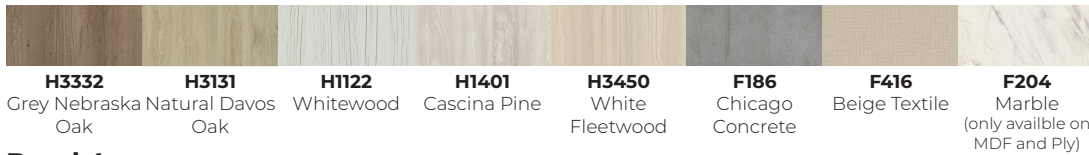

Band 4

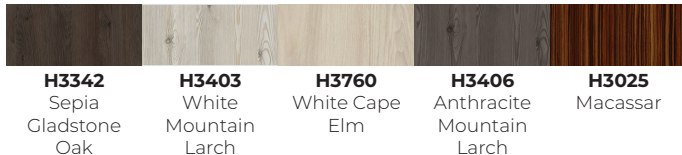

Band 5 - Fenix Nano





















Bespoke

The bespoke option is designed to allow you to consult with our designers on some more unique finishes. The prices will be costed for you as part of that consultation. Minimum order quantities may apply. We have suggested a few possible options.

Richter Light Beton Concretes:
Classic Grey
Classic Anthracite
Urban Grey
Classic White

Electrical Accessories

 <p>PORTHOLE/B/SF</p>	 <p>SURFACE1/B</p>	 <p>PIXEL</p>
 <p>PORTHOLE/B</p>	 <p>SURFACE1/W</p>	 <p>PLUTO</p>
 <p>PORTHOLE/W/SF</p>	 <p>SURFACE2/B</p>	 <p>PULSE</p>
 <p>PORTHOLE/W</p>	 <p>SURFACE2/W</p>	 <p>PATHFINDER</p>
 <p>FACE/B</p>	 <p>LINEAR/B - SOFT FURNISHING</p>	 <p>CABLE TRUNKING & STARTER LEAD</p>
 <p>FACE/W</p>	 <p>LINEAR/W - SOFT FURNISHING</p>	
 <p>INCA/B</p>	 <p>LINEAR/B - FOUR US</p>	
 <p>INCA/W</p>	 <p>LINEAR/W - FOUR US</p>	

Full details and prices on these options can be found in the 2020 price list

Other components and combinations are available (price on application).

Please note that if used with the Kite range of tables that some components may have to be removed if the table is to be folded and moved.

Products are manufactured to enable compliance with BS6396 or BS7671 where relevant.

Tables can be supplied with ready prepared holes for clients to add their own electrics, at a surcharge of £77.00

The positioning of electrical units should be confirmed on all tables prior to order placement.

Fabric Manufacturers



We are proud to work with a large variety of fabric manufacturers to ensure that you can tailor our furniture to perfectly compliment your environment.

Agua
www.aguafabrics.com

Bute
www.butefabrics.com

Camira
www.camirafabrics.com

Chieftain/Just Colour
www.chieftainfabrics.com

Gabriel
www.gabriel.dk

Kvadrat
www.kvadrat.dk

Panaz
www.panaz.com

Svensson
www.ludvigsvensson.com

Skopos
www.skoposfabrics.com

Spradling
www.spradling.eu

Ultrafabrics
www.ultrafabrics.com

Vescom
www.vescom.com

Wildman & Bugby
www.wildmanbugby.co.uk

Yarwood
www.yarwoodleather.com

Environmental & Quality Overview



All products meet SKA rating criteria.



ISO14001 certified environmental management system.



Full accreditation under the Furniture Industry Sustainability Programme.



Ocee Design produce certain chairs with Ecolabel status. All chairs can be supplied with Eco-tex accredited fabrics from Camira.



We actively refurbish and redistribute old products through community groups.



Products are manufactured using CMHR foam.



Ocee Design's manufacturing process and products are low VOC.



All adhesives are water based and biodegradable.



0% material from the Ocee Design manufacturing process is sent to landfill.



Nearly 76% of our components are sourced within 150 miles of our Northampton factory, with 21% within 50 miles.



All Ocee Design products are manufactured using timber sourced from countries whose governments follow statutory reforestation programmes.



All products are a minimum of 95% recyclable and designed for disassembly. Designed for disassembly is both for recycling and ease of refurbishment to extend the life of the product.



FM36814

ISO9001 certified quality management system.



Ocee Design products are offered with a minimum 5 year warranty with 10 years on selected items.



Ocee International Group has committed to the UN17 sustainability goals.

We are delighted to be members and active supporters of the following organisations



Proud to support
The Furniture Makers' Company
the furnishing industry's charity





FM36814 EMS537195

Ocee Design
Design House, Caswell Road
Brackmills Industrial Est.
Northampton, NN4 7PW

London Showroom
20 Old Street
Clerkenwell
London, ECV 9AB

t. 01604 674674
f. 01604 674673
www.oceedesign.com
sales@oceedesign.com

@oceedesign
 @OceeDesign